

C. F. JACOBSON.  
Machine for Making Twist Drills.

No. 201,530.

Patented March 19, 1878.

Fig. 2.

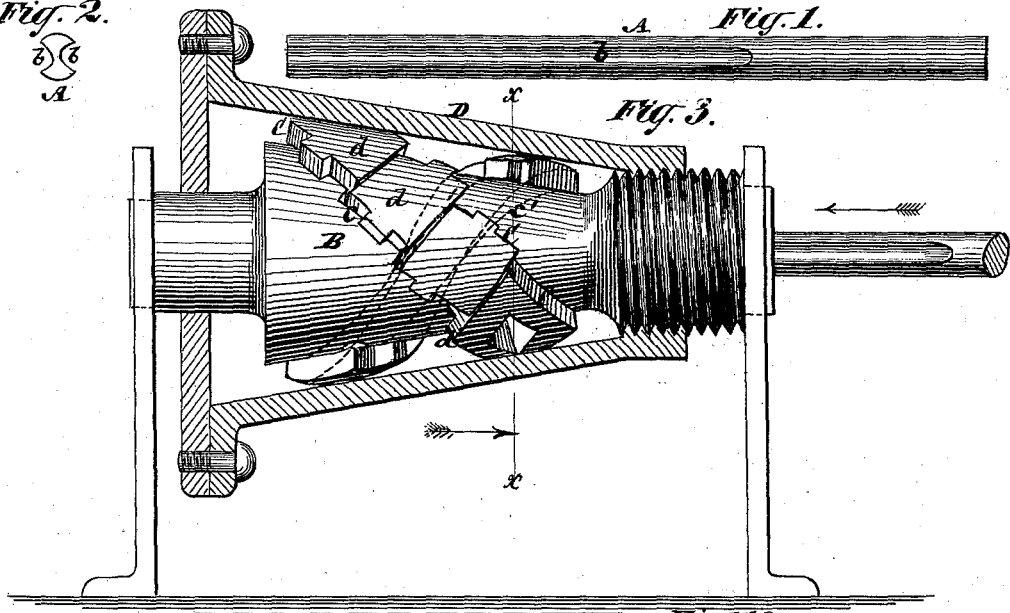

Fig. 3.

Fig. 10.



Fig. 5.

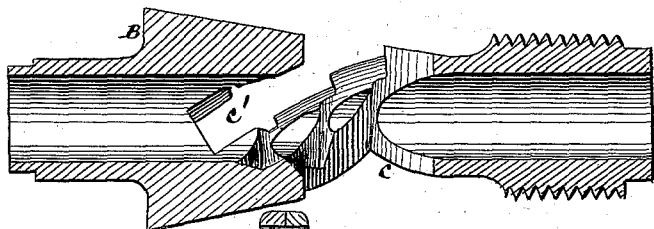

Fig. 6.

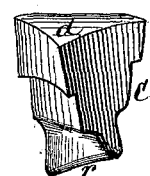

Fig. 4.

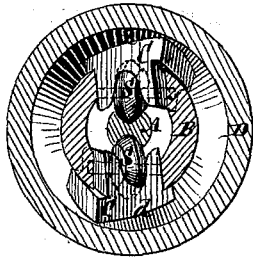

Fig. 7.

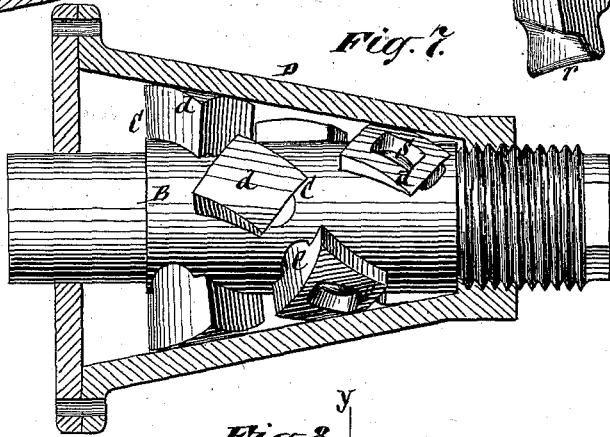

Fig. 9.

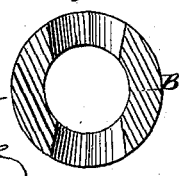
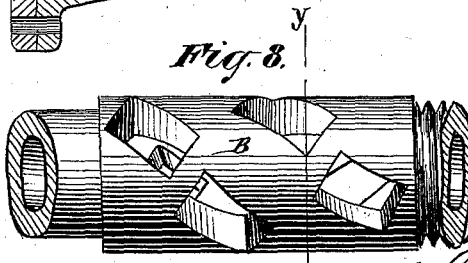

Fig. 8.



Witnesses  
John Beckler  
Fred. Wagner

Inventor  
C. F. Jacobson  
By his Attorneys  
Brown & Allen

# UNITED STATES PATENT OFFICE.

CHRISTIAN F. JACOBSON, OF NEW YORK, N. Y., ASSIGNOR TO HIMSELF  
AND JAMES C. JONES, OF SAME PLACE, AND GEORGE E. MALBY,  
OF NORFOLK, VIRGINIA.

## IMPROVEMENT IN MACHINES FOR MAKING TWIST-DRILLS.

Specification forming part of Letters Patent No. 201,530, dated March 19, 1878; application filed  
February 20, 1878.

### *To all whom it may concern:*

Be it known that I, CHRISTIAN F. JACOBSON, of the city and State of New York, have invented a new and useful Improvement in Devices for Making Twist-Drills, of which the following is a description, reference being had to the accompanying drawings, forming part of this specification.

This invention, like that for which Letters Patent No. 190,592, granted May 8, 1877, to myself, James C. Jones, and George E. Malby, as assignees, and on which it is an improvement, is mainly designed for the manufacture of twist-drills, and will here be more particularly described with reference to such use, although equally applicable to the manufacture of screw-augers. The process or mode of operation in both cases is the same. Thus a drill or auger blank formed with straight grooves parallel with its axis is forced longitudinally through a spiral die or dies, or the latter forced over or along the grooved blank in direction of its axis, to give to said blank the required twist of the drill or auger. Like said patented invention, too, the means used to effect the desired result may comprise a hollow die-holder having longitudinally-arranged spiral slots or openings through it, two or more sectional dies fitted to enter within said slots or openings, and a hollow outer cone or cylinder for holding the dies in place, and preferably made adjustable in direction of its length over the backs of the dies, to regulate the entry of the dies within the die-holder to suit different-sized work, and to facilitate the withdrawal of the twisted blank or blade from the dies—as, for instance, by allowing the twisted blank to drop out of the dies when the whole device has an upright position. Such combinations of means, as in the patent hereinbefore referred to, admit of various changes of construction—as, for instance, making the die-holder and its outer case either of single pieces or in sections, and either conical or straight; also modifications in which the die-holder has combined with it either only two sectional spirally-arranged dies of considerable length or a greater number of said dies of lesser length.

The invention consists in two or more spirally-arranged sectional dies having their acting faces composed of rollers for operation within the grooved blank to be twisted, and whereby the operation of twisting said blank is facilitated, the labor of accurately forming or dressing said acting portions is reduced, inasmuch as the same may be turned up in a lathe, and such acting surfaces or portions may be renewed from time to time by simply substituting one roller or one set of rollers for another without renewing the dies.

Figures 1 and 2 of the drawing represent longitudinal and front-end views, respectively, of a double straight-grooved drill-blank prior to being twisted. Fig. 3 is a partly-sectional longitudinal view of a conical die-holder fitted with a series of sectional dies, and inclosed by an outer hollow cone suitable for producing a twist-drill, and showing a drill-blank as in course of being twisted. Fig. 4 represents a transverse section of the same on the line *x x*; Fig. 5, a longitudinal section of the die-holder, and Fig. 6 a perspective view of a plain die used in said holder. Fig. 7 is a partly-sectional longitudinal view of a modified construction of the die-holder with dies therein, and outer cone or case inclosing the dies; Fig. 8, a longitudinal view of such die-holder detached, and Fig. 9 a transverse section thereof on the line *y y*. Fig. 10 is a longitudinal view of a twist-drill as made by the invention.

Referring, in the first instance, to Figs. 1, 2, 3, 4, 5, 6, and 10 of the drawing, A is a drill-blank, having grooves *b b* rolled, drawn, or otherwise formed lengthwise in it. B is the die-holder, of a conical form, and constructed with duplicate regular or irregular spiral slots *c c'* through it in direction of its length. Said die-holder may be supported and held from turning by any suitable means.

C C are the sectional dies carried within the spiral slots or openings *c c'* of the die-holder. Said dies, which form two spiral series, and, combined, virtually constitute a single spiral die, are fitted loosely within the slots *c c'*, and are of irregular lengths in conformity with the varying diameter of their conical holder, so that they project equally within the

conical holder relatively to its axial line: D is the outer hollow cone or case, arranged to inclose the die-holder and its dies, and serving to give the necessary pressure to keep the dies up to their work, to which end the dies are formed with heads or extended backs *d d*, that also serve to prevent the dies passing wholly through into the die-holder. Such cone or case D is made longitudinally adjustable—as, for instance, by a screw-thread at its one end—over or along the die-holder B, to vary the projection of the dies within the holder before twisting the drill, and to relieve the dies when required to withdraw the drill after it has been twisted.

To twist the drill, the outer case or cone D, as in my former patented invention hereinbefore referred to, is adjusted to retain the dies C C at their proper distance from the axial line of the die-holder B, when said dies are acting upon the blank A through its grooves *b b*. The blank A then, having been suitably heated, is introduced within the forward end of the die-holder, and so that the two opposite forward sectional dies C C enter within or fill the straight grooves *b b* of the blank at the front end of the latter. The blank A is then forced longitudinally through the die-holder in direction of the axis of the latter, thereby causing the several sectional dies C C throughout the length of the die-holder to be received successively within the grooves in the blank A, and so twist the blank in conformity with the spiral directions of the dies, after which the outer case D is slackened to facilitate the extraction of the twist-drill from between the dies and out of the die-holder. Instead, however, of the sectional dies C C, or, at least, all of them, being of a plain construction—that is, with elongated immovable acting faces *r*—as in the patented invention hereinbefore referred to, and as shown here in Fig. 6, to give the twist to the drill-blank as the latter is forced longitudinally through the dies, I provide the acting faces of said dies, or certain of them, with rollers S, the axes of which may be arranged obliquely to the sides of their dies, so that when the dies are in place the rollers S have a spiral arrangement relatively to and around the longitudinal axis of the die-holder, and conform, at the portions of their peripheries which project beyond the dies inside of the die-holder, to the direction of the twist it is required to give the drill-blank as the latter by its grooves *b b* is forced along between the rollers. Thus the rollers S (see Fig. 4) form the acting faces of the spirally-arranged dies, to produce the twist by their entry within the grooves *b b*, as in the case of plain dies, similar to the one shown in Fig. 6, having immovable acting faces. Said rollers, which should be made of hardened steel, may either be of a convex or double beveled construction on their peripheries, and they serve not only to facili-

tate the operation of twisting the drill-blank, and of passing the drill out of the dies after it has been twisted, but, by the convenience with which the rollers may be shaped by turning them in a lathe, the acting faces of the dies which said rollers form may be most accurately produced with very little labor, and whenever such acting faces have become worn or broken, they may be readily replaced by substituting new rollers without throwing away the dies, which are expensive to construct. Thus the rollers applied to the dies conduce very materially to the economy of the whole device, and as the rollers by their rotation change their point of contact with the drill-blanks introduced between them, said movable acting die-faces are very durable.

Either both plain and roller dies may be used in the same holder or all the sectional dies may be fitted with rollers on their acting faces, as described, and shown in Fig. 4.

When there are but two sectional dies of increased length in the same holder, then each of said dies may be fitted with two or more rollers at suitable distances apart along the faces of each of them. Generally, however, it will be preferred to employ a much greater number of sectional dies than two, and to arrange them so that the several rollers in the same spiral course will lie close to one another.

Instead of the spiral slots *c c'* in the die-holder being plain on their edges, they may be stepped, or formed with jogs, as shown in Fig. 3, and the dies be correspondingly constructed to engage with such stepped portions, for the purpose of making each die independent of the other, as regards its support in direction of the spiral slot; or, instead of continuous spiral slots *c c'*, each sectional die may be fitted through a mortise of its own in the holder. These mortises may be formed to give to the dies their requisite spiral arrangement by dividing up the spiral slots *c c'* into a series of sections separated by bridge-pieces, which is the construction shown in Figs. 7, 8, and 9 of the drawings. These last-named figures also show the die-holder as of cylindrical shape and the heads or backs *d* of the dies as of varying thickness, to conform to the taper of the outer conical case, which incloses the die-holder and its dies, the bodies of which latter may be of equal length.

I claim—

The spirally-arranged sectional dies having their acting faces composed of rollers, substantially as and for the purpose herein set forth.

CHR. F. JACOBSON.

Witnesses:

VERNON H. HARRIS,  
FRED. HAYNES.